



## 100-Gbps QSFP28 CWDM4 2km Optical Transceiver

### Features:

- Compliant with IEEE 802.3bm electrical specifications Clause 83E (CAUI-4)
- Compliant with CWDM4 MSA
- Compliant with QSFP28 MSA Specifications, including SFF-8665 Rev. 1.9
- Up to 2km link length over single mode fiber at 100Gbps
- Duplex LC receptacles
- Low power consumption: Max. 3.5W
- BER better than  $10^{-12}$  with FEC-Off
- I<sup>2</sup>C Management Interface
- Hot pluggable electrical interface
- 0 to 70°C case temperature operating range
- Hot pluggable electrical interface
- RoHS-6 Compliant (lead-free)

### Application:

- 100GBASE Ethernet links up to 2km over SMF
- InfiniBand EDR, FDR, & QDR
- HPC Interconnects
- Proprietary Interconnections

### ABSOLUTE MAXIMUM RATINGS

Not necessarily applied together. Exceeding these values may cause permanent damage.

Functional operation under these conditions is not implied.

Parameter	Min	Max	Unit	Note
Storage Temperature	0	85	°C	1
3.3V Power Supply Voltage	-0.3	3.6	V	
Data Input Voltage- Single Ended	-0.3	V <sub>cc</sub> +0.3	V	
Control Input Voltage	-0.3	3.6	V	
Relative Humidity	5	85	%	2

#### Notes:

1. Limited by the fiber cable jacket, not the active ends.
2. Non-condensing.

### Recommended Operating Conditions

Parameter	Min	Typical	Max	Unit	Note
Case Operating Temperature	0		70	°C	
Power Supply Voltage	3.135	3.3	3.465	V	
Data Rate per Channel			25.78125	Gbps	
Bit Error Ratio		$10^{-12}$			
Control Input Voltage High	2.6		3.6	V	
Control Input Voltage Low			0.6	V	
Two Wire Serial (TWS) Interface Clock Rate	0	100	400	kHz	
Differential Data Input / Output Load		100		Ohms	
Link Reach			2000	m	

### Electrical Characteristics

Parameter	Symbol	Min	Typical	Max	Unit	Note
<b>Transceiver Electrical Characteristics</b>						
TRx Power Consumption				3.5	W	
<b>Transmitter Electrical Characteristics</b>						
Data Input Differential Peak-to-Peak Voltage Swing	$\Delta V_{DI PP}$			900	mVpp	
Common Mode Voltage (Max)				1.9	V	
Common Mode Voltage (Min)		0			V	
Differential Input Return Loss		9.5-0.37f, 0.01<=f<8 GHz, 4.75 – 7.4Log <sub>10</sub> (f/14), 8<=f<19 GHz			dB	
Differential to common mode input return loss		22-20(f/25.78), 0.01<=f<12.89 GHz, 15-6(f/25.78), 12.89<=f<19 GHz				
<b>Receiver Electrical Characteristics</b>						
Differential Output Return Loss		9.5-0.37f, 0.1<=f<8 GHz, 4.75 – 7.4Log <sub>10</sub> (f/14), 8<=f<19 GHz			dB	
Differential to common mode output return loss		22-20(f/25.78), 0.01<=f<12.89 GHz, 15-6(f/25.78), 12.89<=f<19 GHz			dB	
Differential Output Voltage				900	mV	
Eye Width		0.57			UI	
Eye Height, Differential		228			mV	

**Optical Characteristics**

Parameter	Symbol	Min	Typical	Max	Unit	Note
<b>Transmitter Optical Characteristics</b>						
Lane Center Wavelengths (Range)	Ch0	1264.5 – 1277.5		nm		
	Ch1	1284.5 – 1297.5				
	Ch2	1304.5 – 1317.5				
	Ch3	1324.5 – 1337.5				
Side-Mode Suppression Ratio	SMSR	30			dB	
Output Optical Power: Average	PO AVE	-6.5		2.5	dBm	
Output Optical Modulation Amplitude, per Lane	OMA	-4		2.5	dBm	1
Extinction Ratio	ER	3.5			dB	
Transmitter Eye Mask		0			%	2
<b>Receiver Optical Characteristics</b>						
Lane Center Wavelengths (Range)	Ch0	1264.5 – 1277.5		nm		
	Ch1	1284.5 – 1297.5				
	Ch2	1304.5 – 1317.5				
	Ch3	1324.5 – 1337.5				
Damage Threshold		3.5			dBm	
Average receive power, Each Lane		-11.5		2.5	dBm	3
Optical Modulation Amplitude (OMA)				2.5	dBm	
Non-stressed Receiver Sensitivity in OMA				-10	dBm	4
Receiver Reflectance				-26	dB	

**Notes:**

1. TDP value and dependent parameters are subject to confirmation.
2. Transmitter eye mask is defined by CWDM4 Specification 1.1.
3. Average receive power, each lane (min) is informative and not the principal indicator of signal strength. A received power below this value cannot be compliant; however, a value above this does not ensure compliance.
4. Measured with conformance test signal at TP3 for BER =  $5 \times 10^{-5}$

QSFP+ Module Pad Assignments and Descriptions

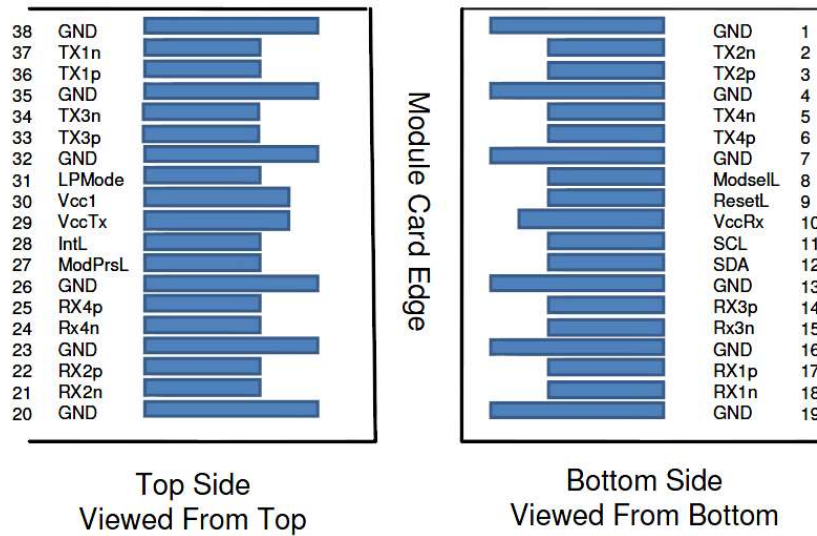

Pin	Logic	Symbol	Description	Plug Sequence	Notes
1		GND	Ground	1	
2	CML-I	Tx2n	Transmitter Inverted Data Input	3	
3	CML-I	Tx2p	Transmitter Non-Inverted Data Input	3	
4		GND	Ground	1	
5	CML-I	Tx4n	Transmitter Inverted Data Input	3	
6	CML-I	Tx4p	Transmitter Non-Inverted Data Input	3	
7		GND	Ground	1	
8	LVTTL-I	ModSell	Module Select	3	
9	LVTTL-I	ResetL	Module Reset	3	
10		Vcc Rx	+3.3V Power Supply Receiver	2	
11	LVC MOS-I/O	SCL	2-wire serial interface clock	3	
12	LVC MOS-I/O	SDA	2-wire serial interface data	3	
13		GND	Ground	1	
14	CML-O	Rx3p	Receiver Non-Inverted Data Output	3	
15	CML-O	Rx3n	Receiver Inverted Data Output	3	
16		GND	Ground	1	
17	CML-O	Rx1p	Receiver Non-Inverted Data Output	3	
18	CML-O	Rx1n	Receiver Inverted Data Output	3	

Pin	Logic	Symbol	Description	Plug Sequence	Notes
19		GND	Ground	1	
20		GND	Ground	1	
21	CML-O	Rx2n	Receiver Inverted Data Output	3	
22	CML-O	Rx2p	Receiver Non-Inverted Data Output	3	
23		GND	Ground	1	
24	CML-O	Rx4n	Receiver Inverted Data Output	3	
25	CML-O	Rx4p	Receiver Non-Inverted Data Output	3	
26		GND	Ground	1	
27	LVTTL-O	ModPrsL	Module Present	3	
28	LVTTL-O	IntL	Interrupt	3	
29		Vcc Tx	+3.3V Power supply transmitter	2	
30		Vcc1	+3.3V Power supply	2	
31	LVTTL-I	LPMode	Low Power Mode	3	
32		GND	Ground	1	
33	CML-I	Tx3p	Transmitter Non-Inverted Data Input	3	
34	CML-I	Tx3n	Transmitter Inverted Data Input	3	
35		GND	Ground	1	
36	CML-I	Tx1p	Transmitter Non-Inverted Data Input	3	
37	CML-I	Tx1n	Transmitter Inverted Data Input	3	
38		GND	Ground	1	

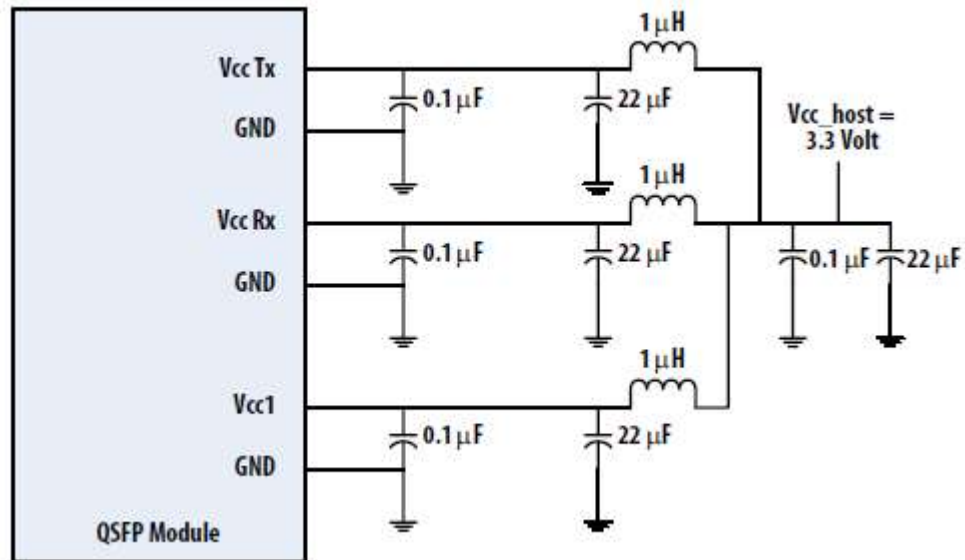
**Recommended Host Board Power Supply Circuit**

Recommended Interface Circuit

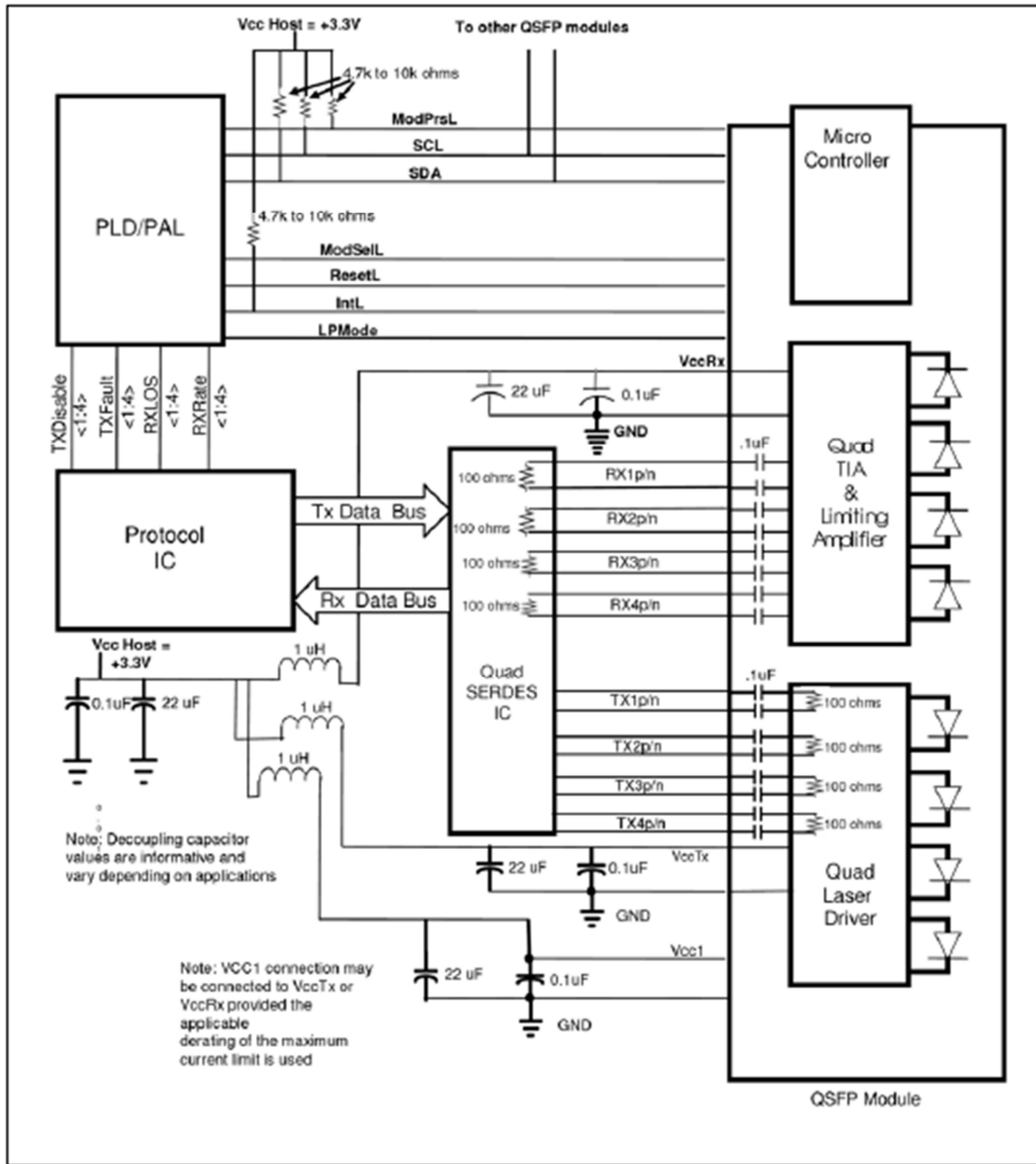

**Mechanical Design Diagram**

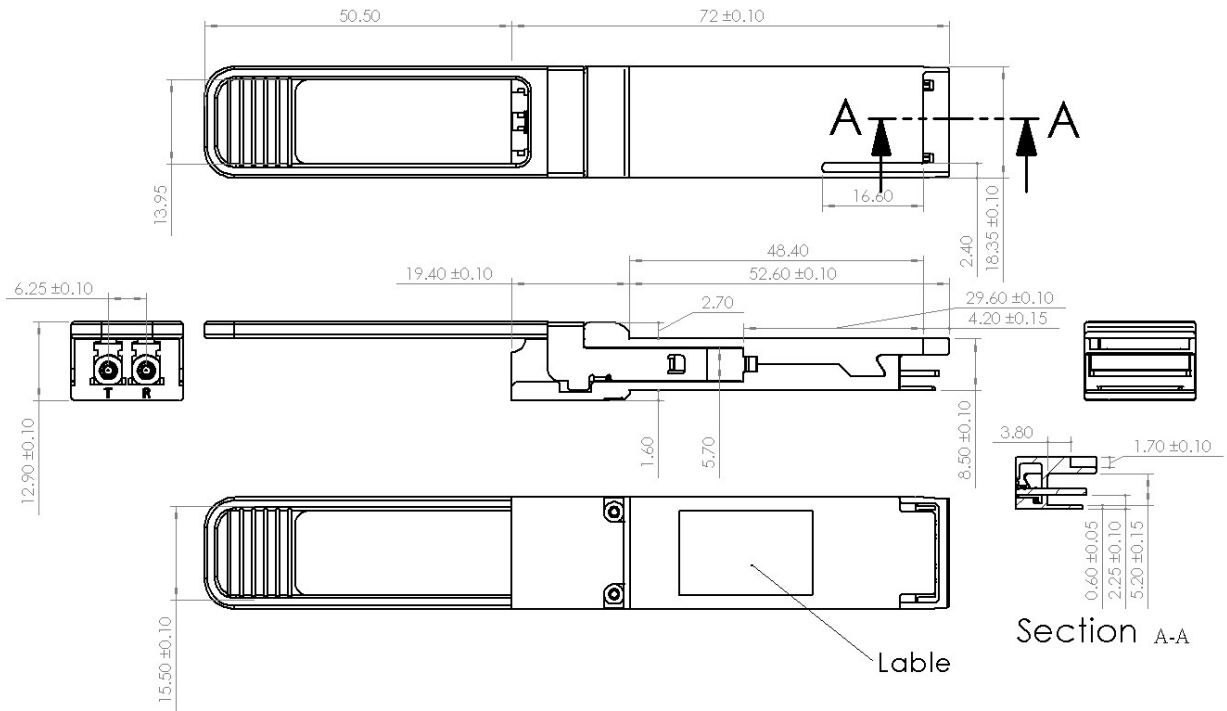

Unit: mm



### Memory Map

The memory map is structured as a single address and multiple page approaches, according to the QSFP+ SFF-8436 MSA specification as shown in the below. For more detailed description of this memory map or lower pages, please see our Memory Map document with flexible customization settings.

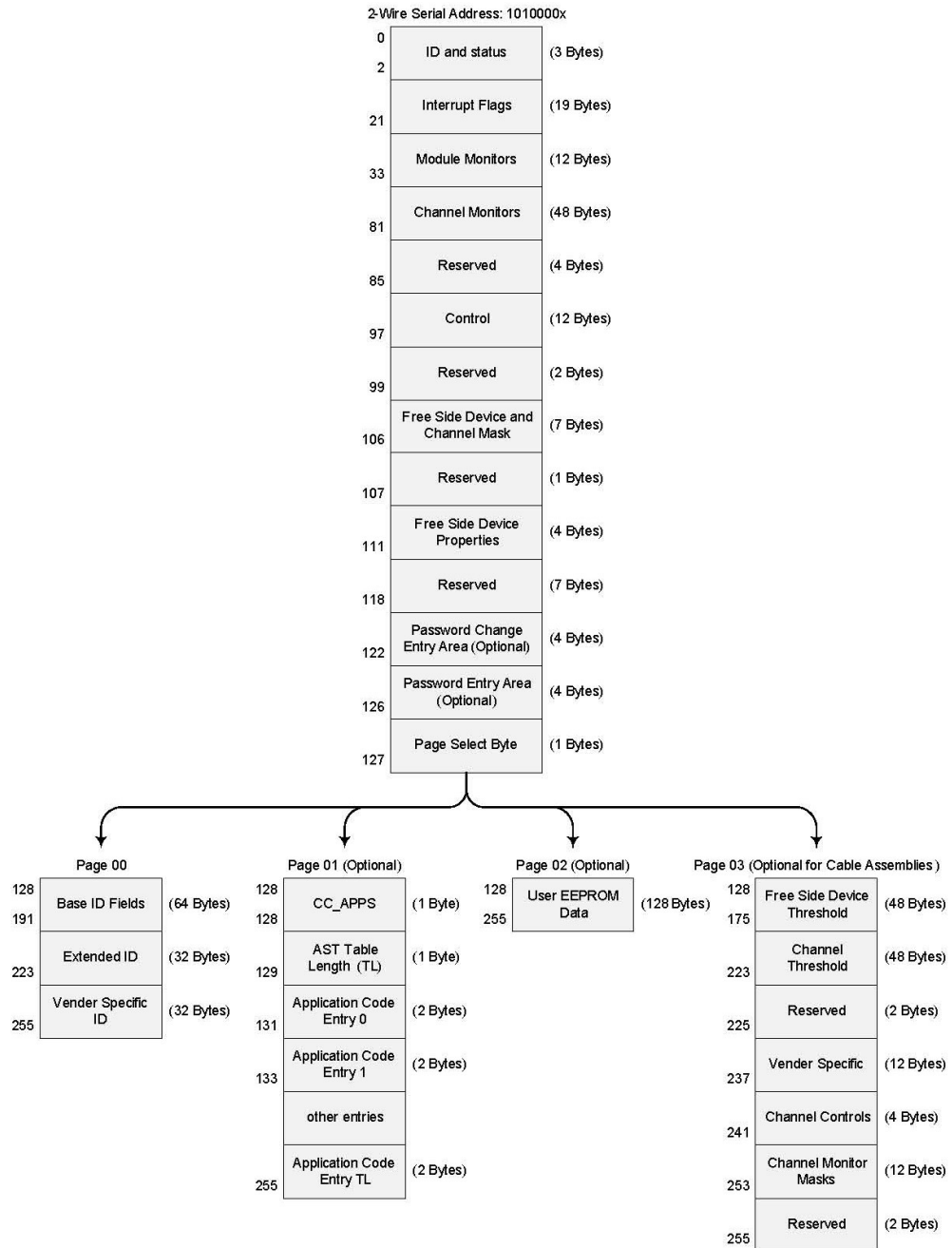

**Sum Up**

Part No	Specification									
	Package	Data rate	Laser	Optical Power (OMA)	Detector	Sensitivity	Temp	Reach	Other	Application code
EGS-QS28-CM4-C	QSFP28	25.78 Gbps each Channel	4-ch CWDM DML	-4.0~2.5 dBm each Channel	PIN	-10dBm each Channel	0~70°C	2km	DDM RoHS	100G Ethernet