



100-Gbps QSFP+ PSM4 Optical Transceiver

Features:

- Compliant with 100G PSM4 Specification 2.0
- Compliant with 100G Ethernet IEEE 802.3bm
- Compliant with SFF-8665 (QSFP28 Solution) Revision 1.8
- MPO optical connector (IEC61754-7-1)
- Operating case temperature (0°C~70°C)
- Transmission length up to 2 km via single mode fiber

Applications:

- Datacenter and enterprise networking
- Switch router and HBA's
- InfiniBand EDR, FDR and QDR
- HPC interconnections

Absolute Maximum Ratings

Parameter	Symbol	Conditions	Min.	Max.	Unit
Storage Temperature	TStorage		-40	+85	°C
Relative Humidity	RH		0	+85	%
Supply Voltage	VCC		0	3.6	V
Power Consumption				3.5	W
Supply Current	Icc			1200	mA

Recommended Operating Conditions (T=25°C, unless noted)

Parameter	Symbol	Conditions	Min.	Typ.	Max.	Unit
Case Temperature	TC		0		70	°C
Power Supply Voltage	VCC		3.15	3.3	3.45	V
Signaling Rate, Each Lane				25.78125		Gbps
Data Speed Tolerance	ΔDR		-100	---	+100	ppm
Power Supply Noise			---	---	50	mVpp
Supply Noise Rejection			---	---	100	mV
Operating Distance	D		---	---	2	km

Transmitter Characteristics (T=25°C, unless noted)

Parameter	Symbol	Conditions	Min.	Typ.	Max.	Unit
Operating Wavelength, each lane	λ	T _c = 0~70 °C	1295		1325	nm
RMS Spectral Width	λ_{rms}				1.5	nm
Average launch power, each lane	PAVG		-9.4		+2	dBm
Optical Modulation Amplitude (OMA), each lane	POMA		-5.15		+2.2	dBm
Difference in launch power between any two lanes (OMA)	Ptx, diff				5	dB
Average launch power of OFF transmitter, each lane	Poff				-30	dBm
Extinction ratio	ER		3.5			dB
Optical return loss tolerance	TOL				20	dB
Transmitter Eye Mask Margin	EMM		5			%

Receiver Characteristics (T=25°C, unless noted)

Parameter	Symbol	Conditions	Min.	Typ.	Max.	Unit
Center Wavelength	λ_C	T _c = 0~70 °C	1295		1325	nm
Damage threshold	THd		+3			dBm
Average Power at Receiver Input, Each Lane			-12.6 6		+2	dBm
Non-Stressed Receiver Sensitivity (OMA), Each Lane	SOMA	BER= 5x10 ⁻⁵			-11.3 5	dBm
LOS Assert	LOSA		-30			dBm
LOS De-Assert	LOSD				-15	dBm
LOS Hysteresis	LOSH		0.5		6	dB

Electrical Characteristics (T=25°C, unless noted)

Parameter	Symbol	Min.	Typical	Max	Unit	Notes
Transmitter						
Differential Input Impedance		90	100	110	Ω	
Differential Input Swing		200		900	mV	
TP1/TP1a Interface	Compliant with IEEE 802.3ba XLPP1					
Receiver						
Differential Output Impedance		90	100	110	Ω	
Differential Output Swing		200		900	mV	
TP4 Interface	Compliant with IEEE 802.3ba XLPP1					

Digital Diagnostic Monitor Functions

Parameter	Symbol	Min.	Max	Unit	Notes
Temperature monitor absolute error	DMI_Temp	-3	3	°C	Over operating temp
Supply voltage monitor absolute error	DMI_VCC	-0.15	0.15	V	Full operating range
Channel RX power monitor absolute error	DMI_RX_Ch	-3	3	dB	Ch1 ~ Ch4
Channel Bias current monitor	DMI_Ibias_Ch	-10%	10%	mA	Ch1 ~ Ch4
Channel TX power monitor absolute error	DMI_TX_Ch	-3	3	dB	Ch1 ~ Ch4

Pin Assignment

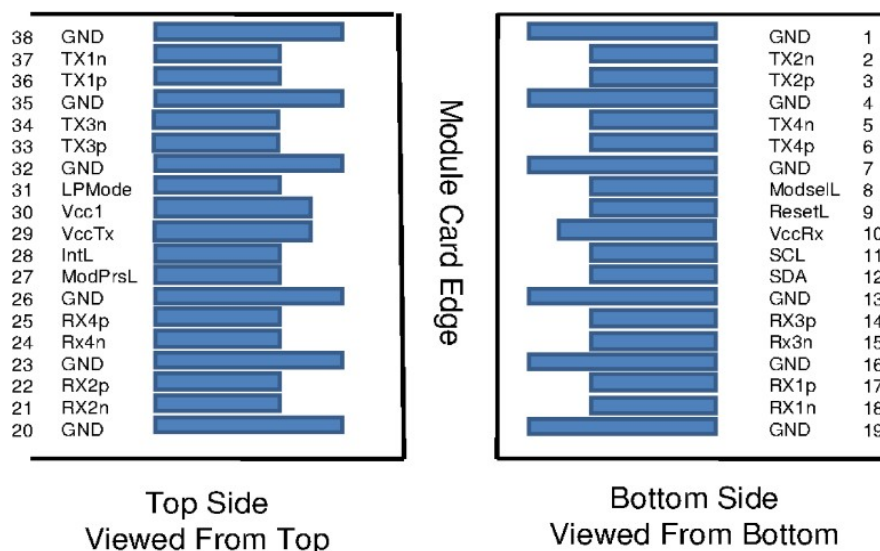

Pin Description

PIN	Logic	Symbol	Name/Description	Note
1		GND	Ground	
2	CML-I	Tx2n	Transmitter Inverted Data Input	
3	CML-I	Tx2p	Transmitter Non-Inverted Data output	
4		GND	Ground	
5	CML-I	Tx4n	Transmitter Inverted Data Input	
6	CML-I	Tx4p	Transmitter Non-Inverted Data output	
7		GND	Ground	
8	LVTTL-I	ModSelL	Module Select	
9	LVTTL-I	ResetL	Module Reset	
10		VccRx	+ 3.3V Power Supply Receiver	
11	LVC MOS-I/ O	SCL	2-Wire Serial Interface Clock	
12	LVC MOS-I/ O	SDA	2-Wire Serial Interface Data	
13		GND	Ground	
14	CML-O	Rx3p	Receiver Non-Inverted Data Output	
15	CML-O	Rx3n	Receiver Inverted Data Output	
16		GND	Ground	
17	CML-O	Rx1p	Receiver Non-Inverted Data Output	
18	CML-O	Rx1n	Receiver Inverted Data Output	
19		GND	Ground	
20		GND	Ground	
21	CML-O	Rx2n	Receiver Inverted Data Output	
22	CML-O	Rx2p	Receiver Non-Inverted Data Output	
23		GND	Ground	
24	CML-O	Rx4n	Receiver Inverted Data Output	
25	CML-O	Rx4p	Receiver Non-Inverted Data Output	
26		GND	Ground	
27	LVTTL-O	ModPrsL	Module Present	
28	LVTTL-O	IntL	Interrupt	
29		VccTx	+3.3 V Power Supply transmitter	
30		Vcc1	+3.3 V Power Supply	
31	LVTTL-I	LPMODE	Low Power Mode	
32		GND	Ground	
33	CML-I	Tx3p	Transmitter Non-Inverted Data Input	
34	CML-I	Tx3n	Transmitter Inverted Data Output	
35		GND	Ground	
36	CML-I	Tx1p	Transmitter Non-Inverted Data Input	
37	CML-I	Tx1n	Transmitter Inverted Data Output	
38		GND	Ground	

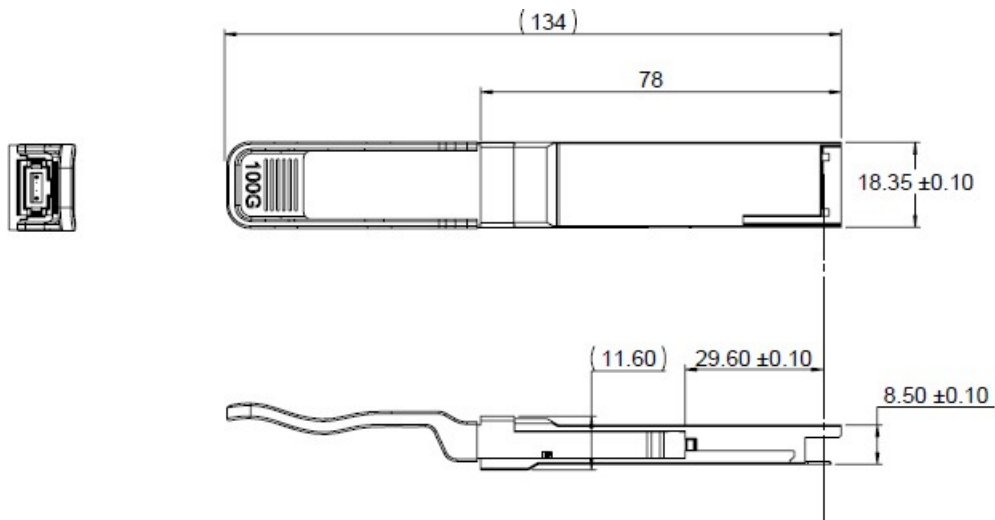
Outline Dimensions

Unit: mm

Attention:

To minimize MPO connection induced reflections, an MPO receptacle with 8-degree angled end-face is utilized for this product. A female MPO connector with 8-degree end-face should be used with this product as illustrated in below.

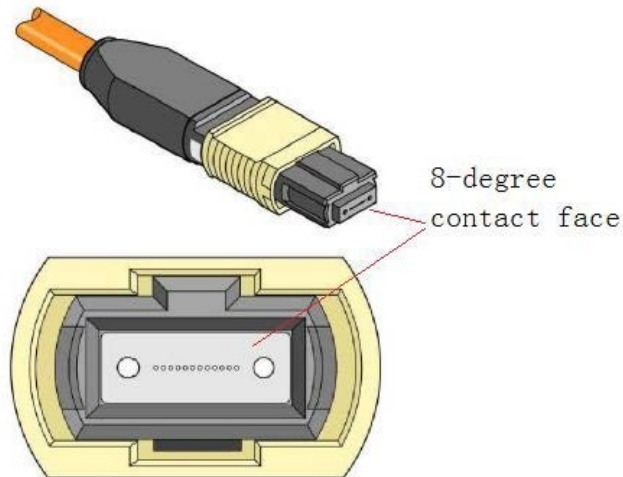

ESD

This transceiver is specified as ESD threshold 1 kV for SFI pins and 2 kV for all others electrical input pins, tested per MIL-STD-883, Method 3015.4/ JESD22-A114-A (HBM). However, normal ESD precautions are still required during the handling of this module. This transceiver is shipped in ESD protective packaging. It should be removed from the packaging and handled only in an ESD protected environment.

Laser Safety

This is a Class 1 Laser Product according to IEC 60825-1:1993: +A1:1997+A2:2001. This product complies with 21 CFR 1040.10 and 1040.11 except for deviations pursuant to Laser Notice No. 50, dated (June 24, 2007)

Sum Up

Part No	Specification									
	Package	Data rate per Lane	Laser	Optical Power (OMA)	PD	Max. Stress Receive Sensitivity	Temp	Reach	Other	Application code
EGS-QS28-P4-C	QSFP28	25.78125 Gbps each Lane	1310nm DFB	-9.4dBm~+2 dBm Each Lane	PIN	-11.35 dBm of Each Lane in OMA for BER 5x10 ⁻⁵	0~70°C	2km	DDM RoHS	InfiniBand EDR, FDR and QDR