



10GBase SFP+ ER/EW Optical Transceivers

Features:

- Optical interface compliant to IEEE 802.3ae 10GBASE-ER/EW
- Compliant with SFP+ MSA
- Data Rate 10.3125 Gbps
- 1550nm EML TOSA with TEC and PIN ROSA
- Applicable for 40 km SMF connection
- LC duplex receptacle
- Low power dissipation (<1.5W)
- Hot Pluggable
- All-metal housing for superior EMI performance
- Built in digital diagnostic Functions
- Operating case temperature range: 0°C~70°C/-40~85°C
- RoHS Compliant

Applications:

- 10GBASE-ER/EW 10Gigabit Ethernet
- 10GBASE-ER/EW+FEC
- 10GE Storage

Absolute Maximum Ratings

Parameter	Symbol	Unit	Min	Max
Storage Temperature Range	T _s	°C	-40	+85
Power Supply Voltage	V _{cc}	V	0	+3.6
Relative Humidity	RH	%	5	95
Optical Receiver Power (Damage)		dBm		5.0

Recommended Operating Conditions

Parameter	Symbol	Unit	Min	Typ	Max
Case Operating Temperature Range-CT	T _{c-CT}	°C	0	25	+70
Case Operating Temperature Range-ET	T _{c-ET}	°C	-5	25	+85
Case Operating Temperature Range-IT	T _{c-IT}	°C	-40	25	+85
Power Supply Voltage	V _{cc}	V	3.135	3.3	3.465
Power Supply Current	I _{cc}	mA		350	450
Power Consumption		mW		1200	1500
Data rate		Gbps		10.3125	11.3

Specifications (tested under recommended operating conditions, unless otherwise noted)

Parameter	Symbol	Unit	Min.	Typ.	Max.	Notes
Electrical Characteristics						
Transmitter Differential Input Voltage	V_{IN}	mV _{pp}	180		700	
Receiver Differential Output Voltage	V_O	mV _{pp}	300		850	
Loss of Signal (LOS)	V_{OH}	V	2		V _{cc}	
	V_{OL}		V _{ee}		V _{ee} +0.8	
Transmitter Disable (TX-Disable)	V_{IH}	V	2		V _{cc}	
	V_{IL}		V _{ee}		V _{ee} +0.8	
Rx Output Rise and Fall Time	T_r/T_f	ps	30			20% to 80%
Optical transmitter Characteristics						
Average Launch Power	P_o	dBm	-1		3	
Center wavelength	λ_c	nm	1530		1565	
Side Mode Suppression Ratio	SMSR	nm	30			
Extinction ratio	E_R	dB	8.2			
Transmitter and dispersion penalty(max)	TDP	dB			2	
Average launch power of OFF transmitted	P_{off}	dBm			-30	
RIN_{12OMA}	RIN	dB/Hz			-128	
Optical Return Loss Tolerance		dB			21	
Output eye	Compliant with IEEE802.3ae eye mask					
Optical receiver Characteristics						
Center wavelength	λ_c	nm	1270		1610	
Average receiver power(max)	P_{max}	dBm			0	
Receiver Reflectance	R_{rx}	dB			-26	
Receiver Sensitivity in OMA		dBm			-16	
LOS	Assert	LOS_A	dBm	-28		
	Deassert	LOS_D	dBm			-19
LOS Hysteresis	LOS_H	dB	0.5			

Digital Diagnostic Memory Map

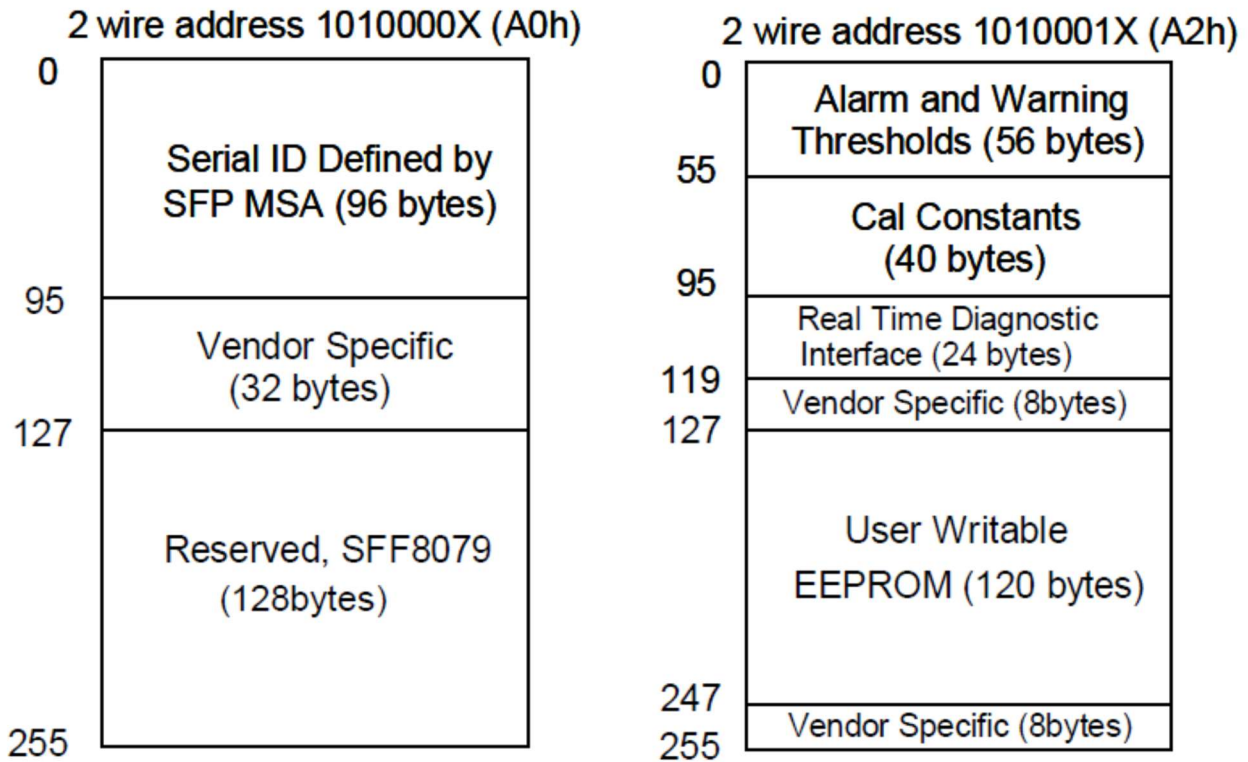

EEPROM Serial ID Memory Contents

Accessing Serial ID Memory uses the 2 wire address 1010000X (A0H). Memory Contents of Serial ID are shown in Table as below.

Serial ID Memory Contents

Data Address	Size (Bytes)	Name of Field	Contents(Hex)	Description
BASE ID FIELDS				
0	1	Identifier	03	SFP
1	1	Ext. Identifier	04	GBIC/SFP function is defined by two-wire interface ID only
2	1	Connector	07	LC Connector
3-10	8	Transceiver	80 00 00 00 00 00 00 00	10GBASE-ER
11	1	Encoding	06	64B/66B

12	1	BR-Normal	67	10.3Gbps
13	1	Rate Identifier	00	unspecified
14	1	Length (9um)- km	28	40km
15	1	Length (9um)	00	
16	1	Length(50um)	00	not support MMF
17	1	Length(62.5um)	00	not support MMF
18	1	Length (Copper)	00	not support copper
19	1	Length(OM3)	00	not support MMF
20-35	16	Vendor name	57 41 56 45 53 50 4C 49 54 54 45 52 20 20 20 20	EGISMOS
36	1	Channel Spacing	00	
37-39	3	Vendor OUI	00 00 00	
40-55	16	Vendor PN	57 53 54 2D 53 46 50 2B 45 52 2D 20 20 20 20 20	EGS-SFP+ER-x
56-59	4	Vendor rev	xx xx xx xx	
60-61	2	Wavelength	06 0E	1550nm
62	1	DWDM Wavelength	00	
63	1	CC Base	xx	Check add. 0 to 62
64-65	2	Options	00 1A	TxDisable, TxFault, LOS implemented
66	1	BR,max	00	
67	1	BR,min	00	
68-83	16	Vendor SN	XXXXXXXXXXXXXXXXXX XXXXXXXXXXXXXXXXXX	
84-91	8	Data code	XXXXXXXXXXXXXXXXXX	

92	1	Diagnostic Monitoring Type	68	Internal cal., Average power
93	1	Enhanced Options	F0	Alarm/Warning flags, Soft TxDisable, Soft TxFault, Soft RxLOS implemented
94	1	SFF-8472 Compliance	03	Rev. 10.0
95	1	CC_EXT	xx	Check add. 64 to 94
96-127	32	Vendor Specific		Vendor Specific EEPROM
128-255	128	Reserved	00	

Pin Definition

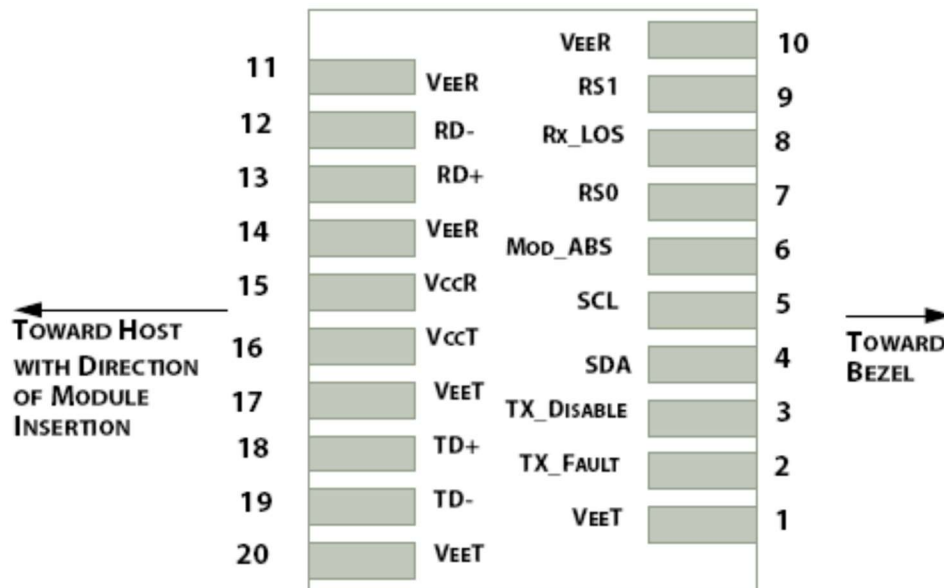

Figure 1: Interface to Host PCB

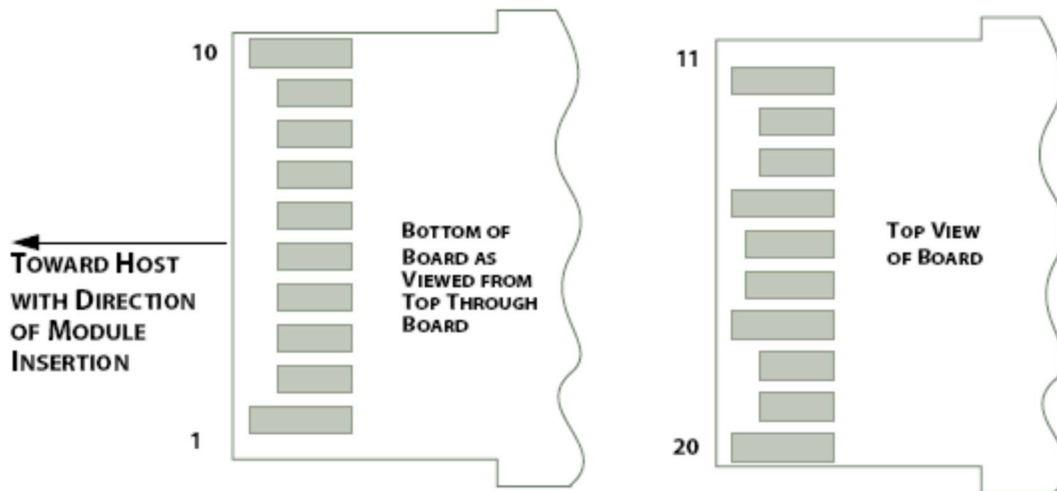

Figure 2: Module Contact Assignment

Module Electrical Pin Definition

Pin	Logic	Symbol	Name/Description	Note
1		VeeT	Module Transmitter Ground	1
2	LVTTL-O	TX_Fault	Module Transmitter Fault	2
3	LVTTL-I	TX_Disable	Transmitter Disable; Turns of transmitter laser output	3
4	LVTTL-I/O	SDA	2-wire Serial Interface Data Line (Same as MOD-DEF2 in the INF-8074i)	
5	LVTTL-I/O	SCL	2-wire Serial Interface Clock (Same as MOD-DEF1 in the INF-8074i)	
6		Mod_ABS	Module Absent, connected to VeeT or VeeR in the module	2
7	LVTTL-I	RS0	Rate Select 0, optionally controls SFP+ module receiver. When high input signaling rate > 4.25 GBd and when low input signal rate ≤ 4.25 GBd.	
8	LVTTL-O	Rx_LOS	Receiver Loss of Signal Indication	2
9	LVTTL-I	RS1	Rate Select 1, optionally controls SFP+ module transmitter. When high input signaling rate > 4.25 GBd and when low input signal rate ≤ 4.25 GBd.	
10		VeeR	Module Receiver Ground	1
11		VeeR	Module Receiver Ground	1
12	CML-O	RD-	Receiver Inverted Data Output	
13	CML-O	RD+	Receiver Non-Inverted Data Output	
14		VeeR	Module Receiver Ground	1

15		VccR	Module Receiver 3.3 V Supply	
16		VccT	Module Transmitter 3.3 V Supply	
17		VeeT	Module Transmitter Ground	1
18	CML-I	TD+	Receiver Non-Inverted Data Output	
19	CML-I	TD-	Receiver Inverted Data Output	
20		VeeT	Module Transmitter Ground	1

Note1: Module ground pins are isolated from the module case and chassis ground within the module.
Note2: Shall be pulled up with 4.7k to 10k ohm to a voltage between 3.15V and 3.45V on the host board.
Note3: Shall be pulled up with 4.7k to 10k ohm to VccT in the module.

Application in System

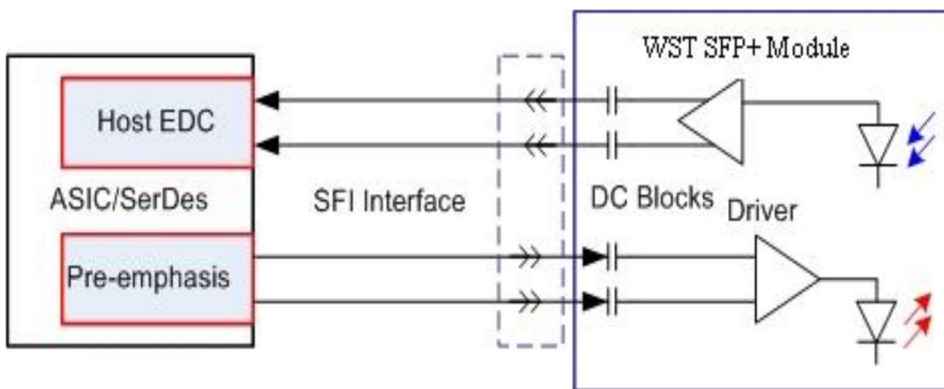

Block Diagram

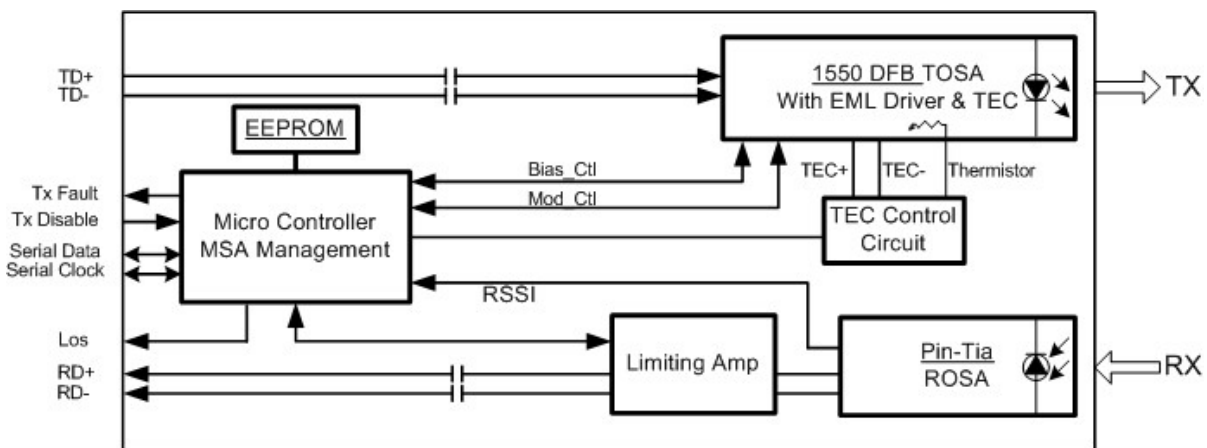

Typical Application Circuit

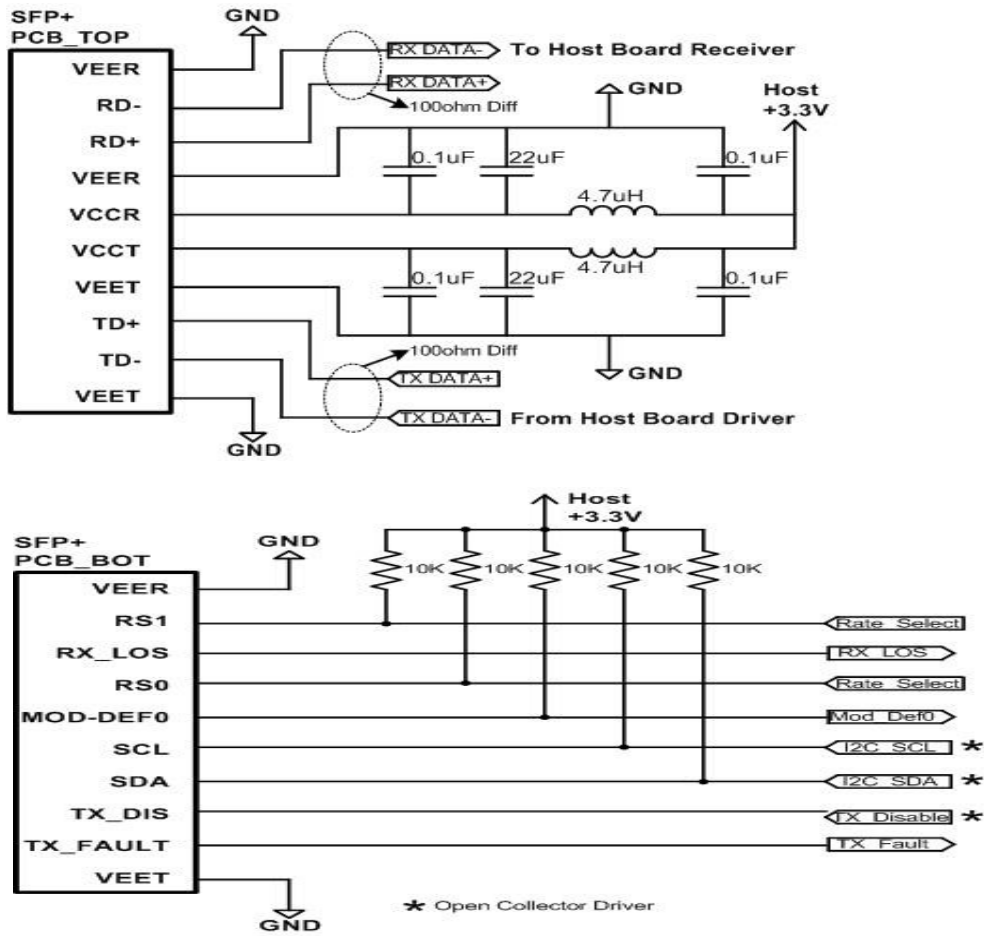

Mechanical

Comply to SFF-8432 rev. 5.0, the improved Pluggable form factor specification.

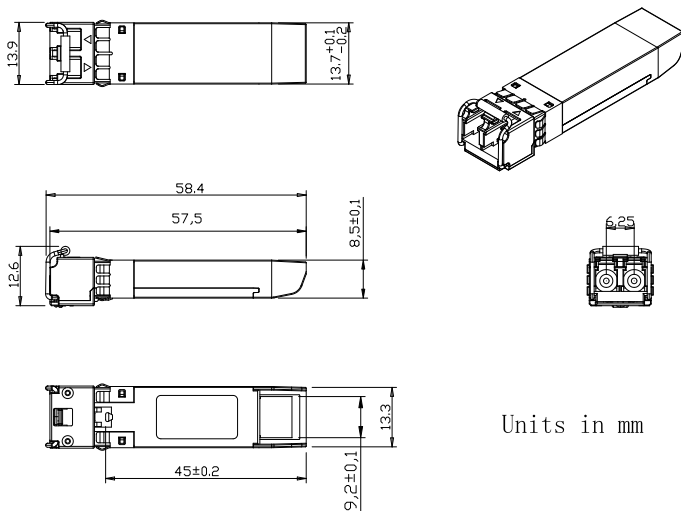

Units in mm

Key Mechanical Dimensions

Designator	Dimension (mm)	Tolerance (mm)	Comments
A	10.00	Recommended Maximum	Module length extending outside of cage, see Note 4. Other lengths are application specific.
B	10.00	Maximum	Designated EMI ground spring area, see Note 5
C	3.00	Maximum	EMI spring/Cage Contact Point, see Note 6
D	14.00	Maximum	Module width extending outside of cage, see Note 4
E	13.55	±0.25	Module width
F	15.50	Maximum	Distance to front end of optional heat sink area, see Note 1
H	1.25	Minimum	Top slot distance from edge, see note 8
J	1.00	Maximum	Top slot depth, see note 8
K	3.25	Reference	Height of module kick-out spring area
L	2.10	Maximum	Module top height extending outside of cage see Note 4
M	2.25	±0.10	Distance from bottom of Module to printed circuit board
N	2.00	±0.25	Distance from rear shoulder to printed circuit board
P	37.10	±0.30	Distance from positive stop to bottom opening of Module and beginning of bottom rear relief

Regulatory Compliance

Feature	Reference	Performance
Electrostatic discharge (ESD)	IEC/EN 61000-4-2	Compatible with standards
Electromagnetic Interference (EMI)	FCC Part 15 Class B EN 55022 Class B (CISPR 22A)	Compatible with standards
Laser Eye Safety	FDA 21CFR 1040.10, 1040.11 IEC/EN 60825-1, 2	Class 1 laser product
Component Recognition	IEC/EN 60950, UL	Compatible with standards
ROHS	2002/95/EC	Compatible with standards
EMC	EN61000-3	Compatible with standards

Sum Up

Part No	Specification									
	Package	Data rate	Laser	Optical Power	Detector	Sensitivity	Temp	Reach	Other	Application code
EGS-SFP+ER-C	SFP+	10.31Gbps~11.3Gbps	1550nm EML	-1~3dBm	PIN	-16dBm	0~70°C	40km	DDM RoHS	10GBASE-ER/EW
EGS-SFP+ER-I	SFP+	10.31Gbps~11.3Gbps	1550nm EML	-1~3dBm	PIN	-16dBm	-40~85°C	40km	DDM RoHS	10GBASE-ER/EW
EGS-SFP+ER-CR	SFP+	10.31Gbps~11.3Gbps	1550nm EML	-1~3dBm	PIN	-16dBm	0~70°C	40km	DDM RoHS	10GBASE-ER/EW With CDR
EGS-SFP+ER-IR	SFP+	10.31Gbps~11.3Gbps	1550nm EML	-1~3dBm	PIN	-16dBm	-40~85°C	40km	DDM RoHS	10GBASE-ER/EW With CDR